

**5-10 ton
ENGINE POWERED
FORKLIFT**



h2000
SERIES **Reliable forklift**

HELI

CHINESE EXPORT BRAND

Recommended
By China Chamber of Commerce for Import and Export of Machinery
And Electric Products

Reliable forklift

A reliable Drive system



As the most reliable transmission system produced by HELI, it has been validated by over twenty years' experience in the world market. Meanwhile, various ancillary devices of the power system ensure the reliability effectively.

- ✓ The mean time between failures for transmission is 8000 hours.
- ✓ Equipped with the intake system
- ✓ Standard distribution of air filter pressure alarm device
- ✓ Automatic engine preheating system
- ✓ Cyclone Air Filter
- ✓ Lost foam casting
- ✓ Various high-power engines are available for customers' optional choices.

A reliable mast



The high internal-qualified mast confirmedly ensures the safety of the operator, truck and cargo. Standard configuration of the wide-view mast enlarges operators' view effectively, and ensures loading /unloading operations more

- ✓ Using the best German steel material for triplex mast
- ✓ The frame of mast has more strength basing on the enlarged channel interface.



A reliable hydraulic system

HELI has the most professional R&D base of cylinders, where we take advantage of the advanced manufacturing technologies and detecting means to ensure the reliability of all cylinders of the hydraulic system.

- ✓ Standard tilt cylinder by HELI
- ✓ Standard lift cylinder by HELI
- ✓ Standard steering cylinder by HELI
- ✓ Self-locking tilt cylinder
- ✓ Standard hydraulic circuit filter
- ✓ Speed-controlling function on lifting system



A reliable steering system

The steering system with new technologies not only provides a smoother swerve and faster positioning & steering, but also effectively ensures operators' safety.



- ✓ Full hydraulic power steering
- ✓ Smaller turning radius
- ✓ Wearable tire

Comfortable operation space

The capacious operating space together with the enormous ergonomic-design and configuration ensure the operation more comfortable & convenient, and effectively enhance the efficiency & safety of operation.

- ✓ Newly patented insulation materials of Bonnet
- ✓ Well-designed non-slip mat
- ✓ Special display with easily reading
- ✓ Standard files packet
- ✓ Standard distribution of overhead guide raincoat
- ✓ Filled with noise-reducing and buffer rubber material between bonnet and frameworks



8-10t WIDE VIEW MAST

Mast model	Max. Fork Height (mm)	Load Capacity (kg)		Overall Mast Height (At Lowered) (mm)		Service Weight (kg)		Tilting Angle (deg.)
		CPCD80	CPCD100	CPCD80	CPCD100	CPCD80	CPCD100	
M250	2500	8000	-	2450	-	10870	-	6-12
M270	2700	8000	-	2550	-	10920	-	6-12
M300	3000	8000	10000	2700	2850	10960	12150	6-12
M330	3300	8000	10000	2850	3000	11020	12215	6-12
M350	3500	8000	10000	2950	3100	11060	12260	6-12
M375	3750	8000	10000	3075	3225	11100	12310	6-12
M400	4000	8000	10000	3250	3400	11310	12450	6-12
M425	4250	8000	10000	3375	3525	11360	12510	6-12
M450	4500	8000	10000	3500	3650	11400	12560	6-12
M475	4750	7750	10000	3625	3775	11450	12620	6-6
M500	5000	7750	10000	3750	3900	11500	12670	6-6
M550	5500	7400	9000	4050	4200	11740	12910	3-6
M600	6000	7000	8000	4300	4450	11830	13020	3-6

8-10t WIDE VIEW FULL FREE 3-STAGE MAST

Mast model	Max. Fork Height (mm)	Load Capacity (kg)		Overall Mast Height (At Lowered) (mm)		Service Weight (kg)		Free lift with Backrest (mm)		Tilting Angle Fwd/Bwd (deg.)
		CPCD80	CPCD100	CPCD80	CPCD100	CPCD80	CPCD100	CPCD80	CPCD100	
ZSM360	3600	7000	8000	2450	2570	11350	12580	1092	1310	6-12
ZSM400	4000	7000	8000	2575	2700	11420	12640	1217	1440	6-12
ZSM435	4350	7000	8000	2700	2820	11490	12700	1342	1560	6-12
ZSM480	4800	7000	7500	2850	2970	11570	12760	1492	1710	6-6
ZSM500	5000	7000	7500	2950	3035	11640	12810	1592	1775	6-6
ZSM540	5400	6600	7000	3075	3225	11710	12880	1717	1965	3-6
ZSM600	6000	6000	6000	3375	3425	12050	12960	2017	2165	3-6
ZSM650	6500	5500	5600	3600	3595	12150	13250	2242	2335	3-6
ZSM700	7000	4500	-	3750	-	12240	-	2392	-	3-6

NOTE: 8t FREE LIFTING HEIGHT WITHOUT LIFT-BRACKET +213mm(10t without backrest)

SIDE SHIFTER ON 10T FREE LIFTING MAST

Mast model	Max. Fork Height (mm)	Load Capacity (kg)	Overall Mast Height (At Lowered) (mm)	Tilting Angle Fwd/Bwd (deg.)	Service Weight (kg)
ZSM360	3600	8000	2570	6-12	12580
ZSM400	4000	8000	2700	6-12	12640
ZSM435	4350	8000	2820	6-12	12700
ZSM480	4800	7500	2970	6-6	12760
ZSM500	5000	7500	3035	6-6	12810
ZSM540	5400	7000	3225	3-6	12880
ZSM600	6000	6000	3425	3-6	12960

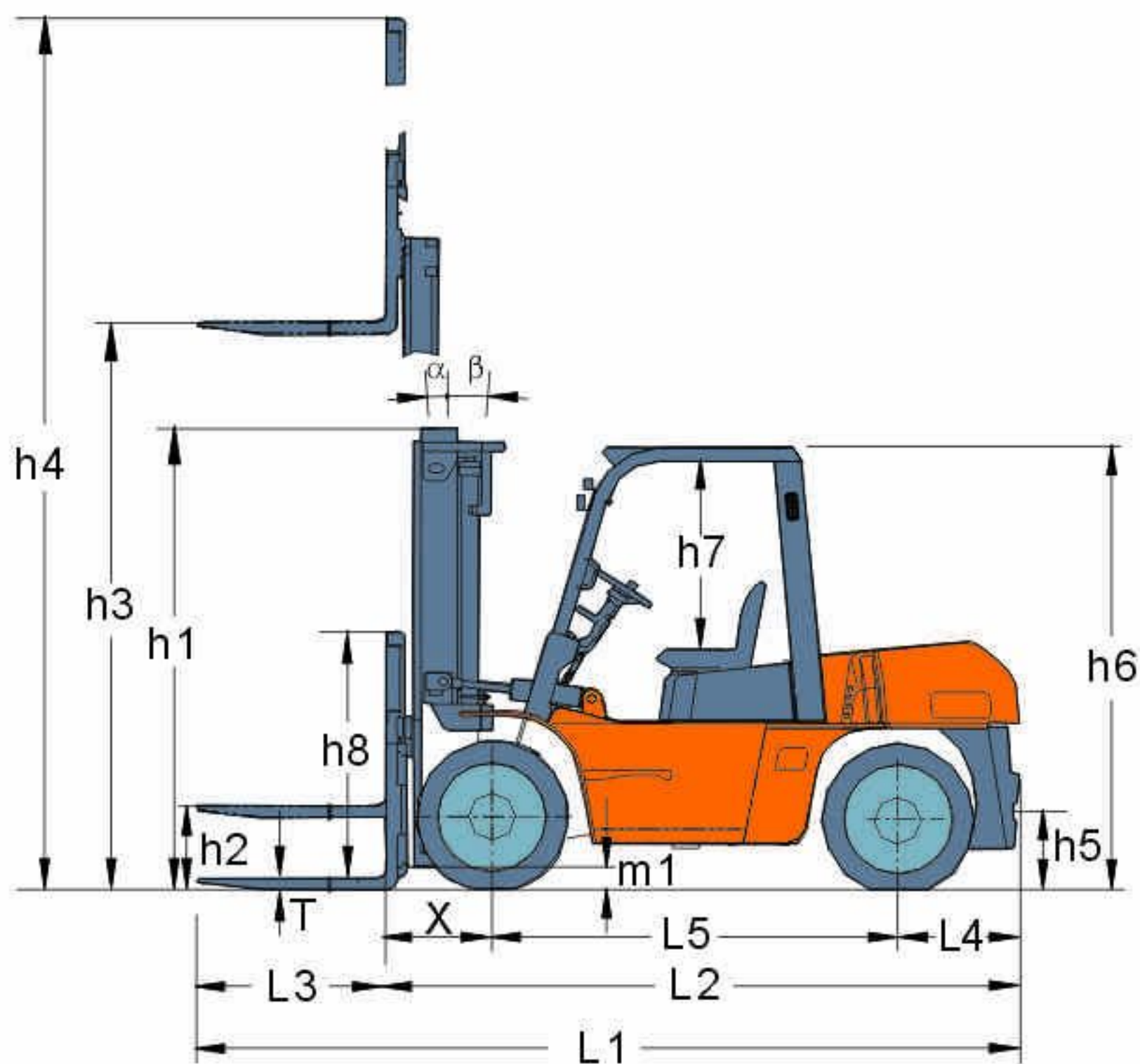

AST: Working aisle width with load
a: Clearance
b: Length of Loading

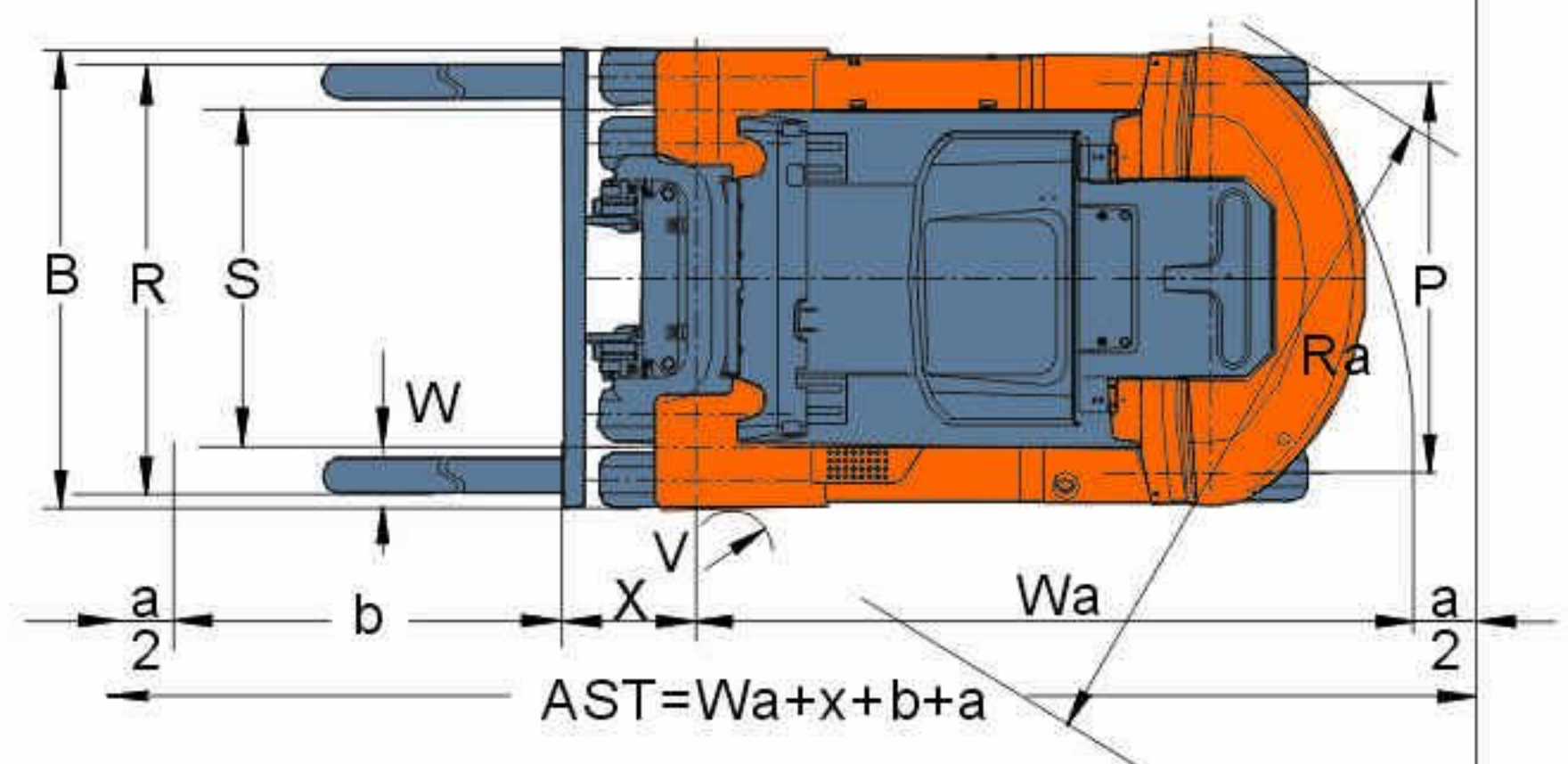

Reliable forklift



5-7t WIDE VIEW MAST

Mast model	Max. Fork Height (mm)	Load Capacity (kg)			Overall Mast Height (At Lowered) (mm)			Service Weight (kg)			Tilting Angle (deg.)
		CPCD50	CPCD60	CPCD70	CPCD50	CPCD60	CPCD70	CPCD50	CPCD60	CPCD70	
M200	2000	5000	6000	7000	2000			7836	8496	9206	6-12
M250	2500	5000	6000	7000	2250			7900	8560	9270	6-12
M270	2700	5000	6000	7000	2350			7930	8590	9300	6-12
M300	3000	5000	6000	7000	2500			7980	8640	9350	6-12
M330	3300	5000	6000	7000	2650			8030	8690	9400	6-12
M350	3500	5000	6000	7000	2750			8060	8720	9440	6-12
M375	3750	5000	6000	7000	2875			8100	8760	9480	6-12
M400	4000	5000	6000	7000	3050			8270	8930	9650	6-12
M425	4250	5000	6000	7000	3175			8310	8970	9690	6-12
M450	4500	5000	6000	7000	3300			8350	9010	9730	6-12
M475	4750	5000	6000	7000	3425			8390	9050	9770	6-6
M500	5000	5000	6000	7000	3550			8430	9090	9810	6-6
M550	5500	4750	5700	6600	3850			8630	9290	10000	3-6
M600	6000	4400	5400	6400	4100			8710	9370	10080	3-6

5-7t WIDE VIEW FULL FREE 2-STAGE MAST

Mast model	Max. Fork Height (mm)	Load Capacity (kg)			Overall Mast Height (At Lowered) (mm)			Service Weight with Backrest (kg)			Free lift with Backrest (mm)	Tilting Angle Fwd/Bwd (deg.)
		CPCD50	CPCD60	CPCD70	CPCD50	CPCD60	CPCD70	CPCD50	CPCD60	CPCD70		
ZM250	2500	5000	6000	7000	2210			8010	8670	9380	837	6-12
ZM270	2700	5000	6000	7000	2310			8040	8700	9410	937	6-12
ZM300	3000	5000	6000	7000	2460			8090	8750	9460	1087	6-12
ZM330	3300	5000	6000	7000	2610			8140	8800	9510	1237	6-12
ZM350	3500	5000	6000	7000	2710			8170	8830	9540	1337	6-12
ZM375	3750	5000	6000	7000	2835			8210	8870	9580	1462	6-12
ZM400	4000	5000	6000	7000	3010			8370	9030	9740	1637	6-12
ZM425	4250	5000	6000	7000	3135			8410	9070	9780	1762	6-12
ZM450	4500	5000	6000	7000	3260			8450	9110	9820	1887	6-12
ZM475	4750	5000	6000	7000	3385			8490	9150	9860	2012	6-6
ZM500	5000	5000	6000	7000	3510			8530	9190	9900	2137	6-6
ZM550	5500	4750	5700	6700	3810			8730	9390	10100	2437	3-6
ZM600	6000	4400	5400	6400	4060			8810	9470	10180	2687	3-6

NOTE: 5-6tFREE LIFTING HEIGHT WITHOUT LIFT-BRACKET +465mm
7tFREE LIFTING HEIGHT WITHOUT LIFT-BRACKET +310mm

5-7t WIDE VIEW FULL FREE 3-STAGE MAST

Mast model	Max. Fork Height (mm)	Load Capacity (kg)			Overall Mast Height (At Lowered) (mm)			Service Weight with Backrest (kg)			Free lift with Backrest (mm)	Tilting Angle Fwd/Bwd (deg.)
		CPCD50	CPCD60	CPCD70	CPCD50	CPCD60	CPCD70	CPCD50	CPCD60	CPCD70		
ZSM360	3600	4500	5600	6200	2335			8670	9330	10020	962	6-6
ZSM400	4000	4500	5600	6200	2470			8730	9390	10080	1097	6-6
ZSM435	4350	4500	5600	6200	2585			8790	9450	10120	1212	6-6
ZSM480	4800	4500	5600	6200	2740			8980	9640	10310	1367	6-6
ZSM500	5000	4500	5600	6200	2805			9010	9670	10340	1432	3-6
ZSM540	5400	4200	5300	6000	2940			9080	9740	10510	1567	3-6
ZSM600	6000	4000	5000	5500	3140			9170	9830	10690	1767	3-6
ZSM650	6500	3600	4300	4500	3405			9280	9940	10810	2032	3-6
ZSM700	7000	3000	3500	3700	3515			9390	10050	10920	2142	3-6

NOTE: 5-6tFREE LIFTING HEIGHT WITHOUT LIFT-BRACKET +465mm
7tFREE LIFTING HEIGHT WITHOUT LIFT-BRACKET +310mm

Reliable special designed instrument

The reliable special instrument gives a complete display of the vital information, like operation status, fault detection, etc. It ensures the operator predominate the vehicle status more intuitive and convenient.

- ✓ Stepping motor core
- ✓ Programmable LCD
- ✓ Electrical safety standard meets CE requirements

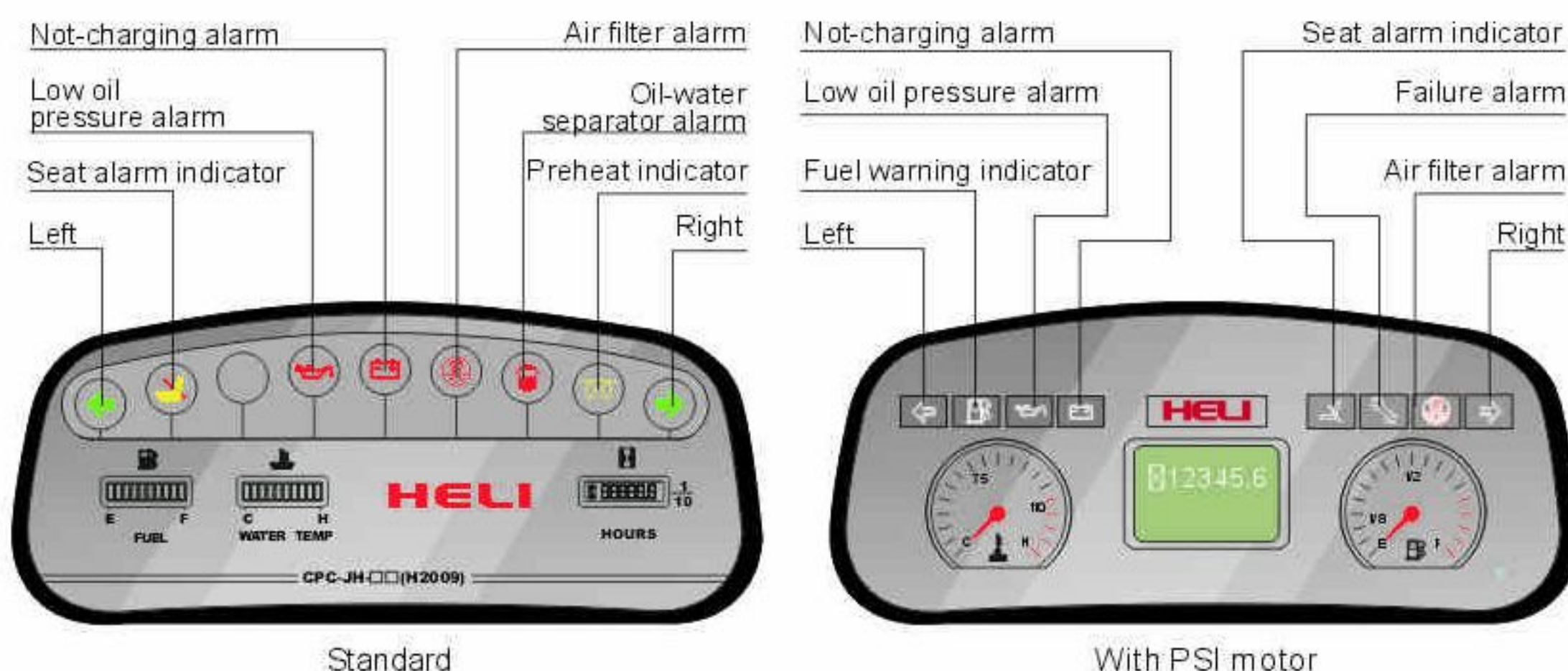

Standard

With PSI motor

Reliable forklift



5-10 ton
**ENGINE POWERED
FORKLIFT**

STANDARD EQUIPMENT

Back view mirror	Air filter block alarm
Horn	Ancillary water tank,radiator
Lift and tilt stick	Full hydraulic power steering
Standard seat	Hydraulic oil gauge
Cable rod	Transmission oil gauge
Air filter	Oil pressure alarm
Stick	Wide-view Mast
Cushion of the pedal	Control valve (two-throw)
Oil meter	Digital combined instrument
Back view mirror	Rear component light
Attached tools	Upper and lower air inlet system
Side roller	Engine extinction device
Backward buzz	Neutral position indicator
Overhead lamp	Overhead guide raincoat
Traction bar	Battery-charge indicator
Lamp protector	Water temperature meter
Steering indicator	Self-locked valve on tilt oil way
Hour meter	Overhead guide raincoat
Standard fork	
Backward lamp	

OPTIONS

Cab	Turning flat dip
Boom	Heater in the cab
Load hook	Power shift
Load bar	Double air-filter
Side shifter	Color tyre(white,green)
Clamp	Multi function barrel clamp
Spark Arrester Muffler	Customer referred color
Damp container	Low smoke anti-fire muffler
Turning alarm light	Wide view double (triplex) mastwith full free length
Wind-proof glass	Operator persence sensing
Damp fork	
Extinction	
Solid tyre	
Heater	
Widened fork holder	
Suspend seat	
Lengthened sleeve on fork	
High positioned	



TOP1 FORKLIFT MANUFACTURING AND SALE
IN CHINA CONTINUOUSLY FOR 20 YEARS